

PV2000 Series Valveplate Modulating **Pumps**

Also refer to "Pump Features, Selection and Operating Recommendations" ([dynexpumpoperating.pdf](#))

CONTACT INFORMATION

USA Headquarters

Dynex/Rivett Inc.
770 Capitol Drive
Pewaukee, WI 53072 U.S.A.
Tel: 262-691-2222
FAX: 262-691-0312
E-mail: sales@dynexhydraulics.com

Power Units & Systems

Dynex/Rivett Inc.
54 Nickerson Road
Ashland, MA 01721 U.S.A.
Tel: 508-881-5110
FAX: 508-881-6849
E-mail: ashland@dynexhydraulics.com

European Sales

Dynex/Rivett Inc.
Unit C5 Steel Close, Little End Road, Eaton Socon,
Huntingdon, Cambs. PE19 8TT United Kingdom
Tel: +44 (0) 1480 213980
FAX: +44 (0) 1480 405662
E-mail: sales@dynexhydraulics.co.uk

For more information
visit our web site:
www.dynexhydraulics.com

BROCHURE NOTES:

Maximum pressures indicated throughout are the maximum intermittent pressures a component can sustain for occasional, short periods of operation without appreciably reducing the life expectancy. Contact the Dynex sales department for a review of any application which requires operating above the rated pressures, flows, speeds or higher than normal operating temperatures.

Specifications shown were in effect when published. Since errors or omissions are possible, contact your sales representative for the most current specifications before ordering. Dynex reserves the right to discontinue products or change designs at any time without incurring any obligation.



Electro-Hydraulic Pumps and Motors For Accurate, Remote Speed Control

Dynex valveplate pumps and motors are used in demanding applications requiring accurate control, and resistance to dust, dirt, vibration and difficult duty cycles.

PV2000 SERIES PUMPS – These pumps provide a perfect combination of accurate electro-hydraulic control, long service life and high efficiency operation.

On electro-hydraulic modulating models, output flow is proportional to a variable electrical input signal. Other models are available with pressure compensation, remote controlled compensation, load sensing and economical on/off control.

MF2000 AND MV2000 MOTORS – These motors produce high torque relative to their compact size. The largest weighs 38 lb (17,2 kg) and produces up to 62 hp at 3000 psi (46 kW at 210 bar).

Variable models provide two speeds. A solenoid valve de-strokes the motor to its lower displacement, providing increased speed.

MF5000 SERIES MOTORS – Heavy-duty motors produce steady power with smooth speed variation.

They keep operating even when subjected to extreme pressure spikes, severe vibration and tough duty cycles. They are ideal for systems with constant starting and stopping, and sudden direction reversals.

For information on motors refer to [dynexpesmfmvspecs.pdf](#)

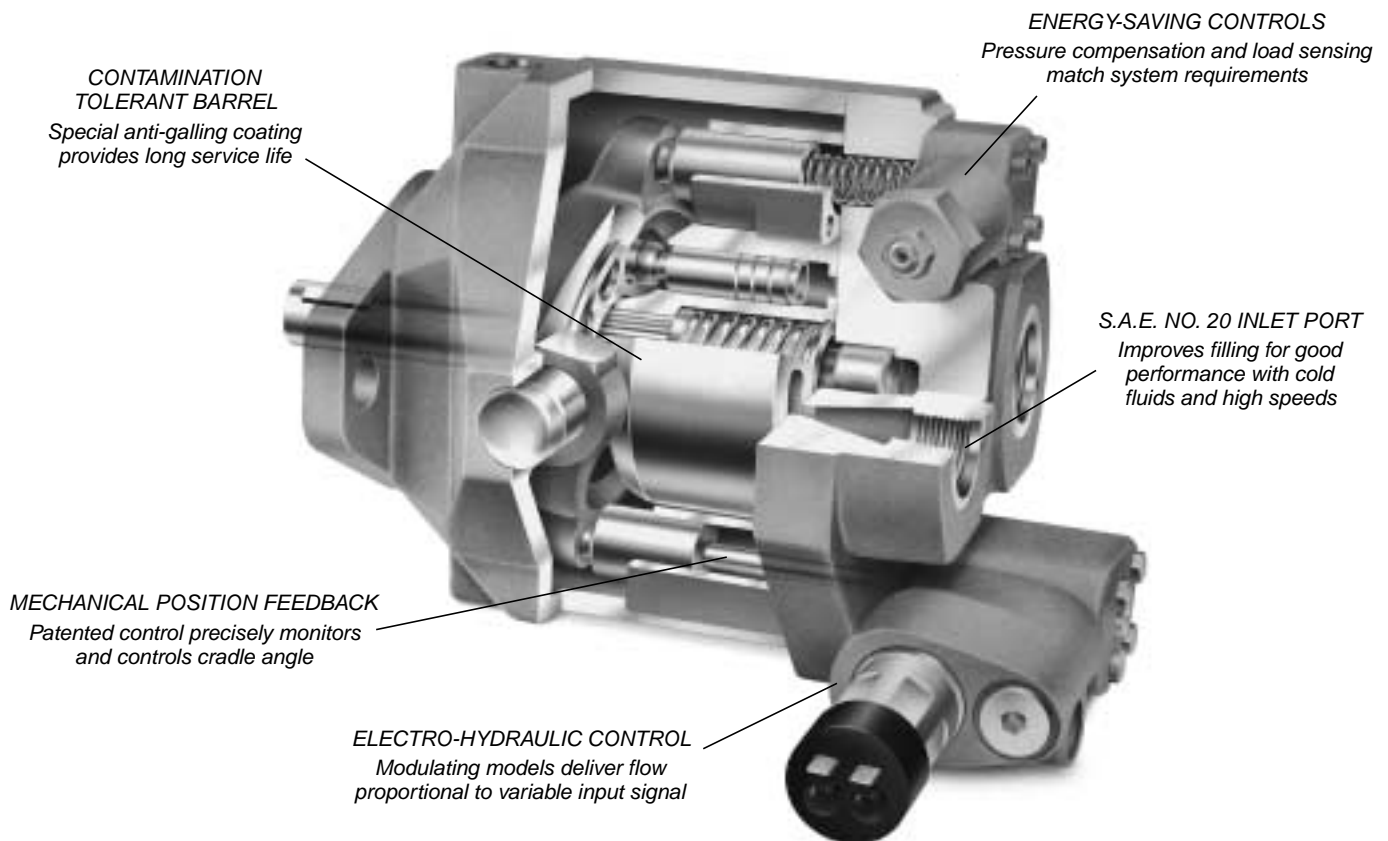

PV2 Series Electro-hydraulic Modulating Pump

Reliable Modulating Pumps For Long, Difficult Duty Cycles

PV2000 Series pumps, with their durable construction yet simple electro-hydraulic design, provide long, reliable service life.

Modulating pumps, with accurate output, feature a patented design requiring no additional electronic feedback. The rugged design provides dependable operation in adverse conditions including extreme heat, dirty environments and difficult duty cycles.

ACCURATE FLOW CONTROL

Electro-hydraulic modulating models deliver flow proportional to an electrical input signal.

Patented *mechanical position feedback* continuously monitors and adjusts pump output during operation. A mechanical linkage between cradle position and the force motor provides accurate control of pump output. The result is closed control-loop accuracy without additional electronic feedback.

Machines can use position sensors or micro-processor input for automatic control; or functions can be controlled with manual input. Components can be located where it's most convenient, with hydraulics remotely controlled by the operator.

LONG SERVICE LIFE

These pumps operate reliably in harsh operating conditions. Piston barrels treated with a special anti-galling coating provide superior contamination tolerance.

Internal shafts with 1 inch (25,4 mm) diameters and extra large inlet ports, for improved filling characteristics, enable these pumps to keep running under adverse conditions.

PUMP CONTROL OPTIONS

PV2000 Series pumps are available in three displacements, with a choice of controls:

Pressure Compensation

Maintains a preset maximum pressure, adjustable from 500 to 3500 psi (35 to 245 bar). These models include an integral stroke limiter for convenient adjustment of maximum pump output.



PV2000 Series Pump
With Electro-hydraulic
Modulating Control

Remote Compensator

Offers the convenience of remotely regulating maximum pressure from the operator's station.

Load Sensing

Automatically provides the output required by the function at a pressure 150 to 300 psi (10,4 to 20,7 bar) higher than load pressure.

On/Off Control

Brings pump on-stroke and off-stroke in response to an electrical signal. On/off models come with standard pressure compensator. Maximum output can be set using an integral stroke limiter control.

Modulating Control

Delivers flow proportional to a variable electrical input signal. Modulating pumps come with standard pressure compensator override.

PUMP SPECIFICATIONS

Output at 1800 rpm, 3000 psi (210 bar)

Model PV2024:
17.7 U.S. gpm (67,0 L/min);
Model PV2029:
21.5 U.S. gpm (81,4 L/min);
Model PV2032:
24.5 U.S. gpm (92,7 L/min)

See "Typical Performance Curves" on page 8 for maximum output.

Rated Pressure

Rated: 3000 psi (210 bar);
Maximum Intermittent: 4000 psi (280 bar). Note that adjustment of the compensator is limited to 3500 psi (245 bar) maximum. For intermittent operation above 3500 psi (245 bar) contact the Dynex sales department.

Rated Speed

All Models: 2000 rpm

Maximum Speed

Models PV2024, PV2029: 2800 rpm;
Model PV2032: 2600 rpm

Required External Pilot Supply (Electro-Hydraulic Models)

Pressure: 200 psi (13,8 bar);
Flow: 0.2 gpm (0,8 L/min)

FORCE MOTOR ELECTRICAL DATA

Description	Specifications ^①
Rated voltage	± 12 V (D.C.)
Full Stroke Voltage	± 9 V (D.C.)
Rated Input Current	490 mA
Resistance	24.5 Ohms
Wattage	5.9 Watts
Inductance at 1.0 kHz	60 mH
Recommended Dither Signal ^②	± 3 V (D.C.) 60 Hz Square Wave

^① Specifications at 70° F (21° C)

^② A dither signal is recommended to improve response time and reduce hysteresis. A pulse width modulation signal can also be used to improve performance.

Electro-Hydraulic Pump Operation

ACCURATE OUTPUT FLOW

Modulating models deliver flow proportional to a variable electrical signal supplied to a force motor in the pilot-stage. The force motor is an

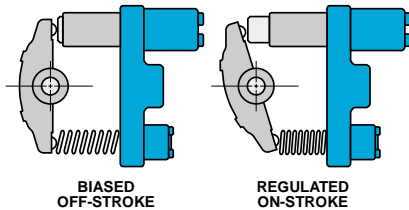

Cradle movement in modulating pumps is controlled by a variable electrical signal supplied to the pilot-stage force motor.

electro-magnetic device with an armature that moves in response to the magnitude of the electrical signal.

The armature controls the movement of a pilot spool which ports pilot flow to the pump control piston. An external pilot supply of 0.2 gpm at 200 psi (0,8 L/min at 13,8 bar) is required.

The pump cradle in these models is biased to an off-stroke position. The control piston moves to bring the pump on-stroke, in response to the electrical signal supplied to the force motor.

As the electrical signal is increased, pump output is proportionally increased, up to full flow. Reducing the signal decreases pump output.

For any applied electrical signal, there is a distinct position for the cradle. Pressure to the control piston is automatically regulated to maintain the commanded cradle position.

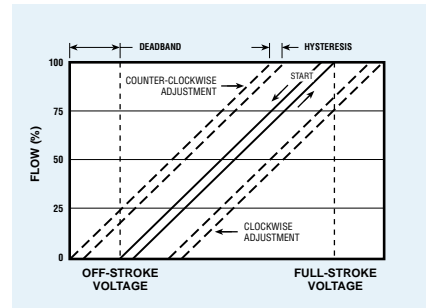

Pump output can be illustrated by a "flow versus current" curve. Deadband, or the amount of signal required to initiate flow, can be adjusted by rotating the force motor.

MECHANICAL POSITION FEEDBACK

Cradle angle, and resulting pump output, is accurately monitored and controlled by patented *mechanical position feedback*. See the drawings below for a description of how this design operates.

FIGURE 1: The mechanical position feedback design consists of a feedback rod (attached to the control piston) and a pilot sleeve which rides on a feedback cam in the rod. A hole in the sleeve, in conjunction with the land on the spool, forms a control orifice. When no flow is required this orifice is closed.

FIGURE 2: In response to the electrical signal, the force motor armature retracts. The pilot spool, held in contact with the armature, moves inside the sleeve directing pilot flow to the control piston through the now open orifice. Movement of the piston changes the cradle angle and brings the pump on-stroke.

FIGURE 3: The feedback rod moves with the control piston. When the cradle has reached its proper angle, movement of the feedback cam causes the sleeve to shift in relation to the spool. This closes the orifice and effectively nulls the pilot stage. The control piston and the cradle remain in this position as long as the electrical signal is unchanged.

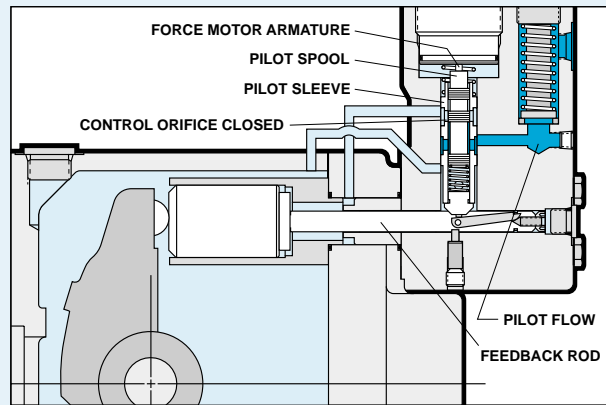

Figure 1: Cradle biased off-stroke

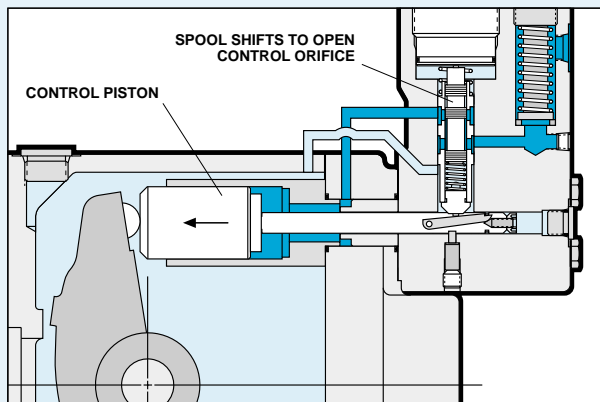

Figure 2: Pilot flow ported through control orifice

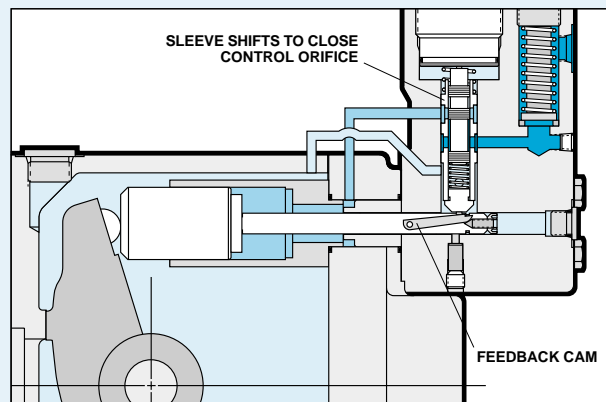

Figure 3: Movement of sleeve nulls pilot stage

PV2000 SERIES PUMPS

Pump Type

Variable displacement valveplate design with a choice of controls to regulate delivery.

Mounting

S.A.E. B 2-bolt pattern

Shaft Data

Standard, S.A.E. B-B 1.00 inch keyed shaft,
or S.A.E. B-B spline shaft:
1.000/.978 inch diameter standard
S.A.E. 15 tooth, 16/32 D.P. 30° involute spline;
Optional S.A.E. B Spline Shaft:
.875/.853 inch diameter standard
S.A.E. 13 tooth, 16/32 D.P. 30° involute spline.

Weight (Mass)

Compensated: 56 lb (25,4 kg);
On/Off: 59 lb (26,8 kg);
Modulating: 64 lb (29,0 kg);
Thru-Shaft: 75 lb (34,0 kg)

SELECTING PV2 SERIES PUMPS

The table below indicates which controls are available for each pump size.

STANDARD PUMPS – Control options are shown for models with both rotations (as viewed from shaft-end).

Model numbers listed are for pumps with standard S.A.E. B-B 1.00 inch keyed shafts or standard S.A.E. B-B spline shafts. For pumps with optional S.A.E. B spline shaft contact your Dynex representative for specific model numbers.

THRU-SHAFT PUMPS – Thru-shaft models can reduce circuit costs by eliminating separate drives, saving space and reducing installation time.

These models are available in a tandem configuration or as a single thru-shaft pump. Any accessory

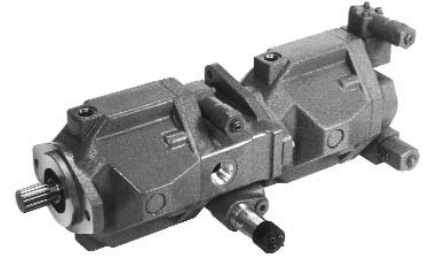

Tandem Thru-Shaft PV2000 Series Pumps

pump, with a standard S.A.E. B 2-bolt pattern, can be mounted “piggy-back”. The internal coupling is a standard S.A.E. B-B spline.

Thru-shaft pumps are available with a choice of control options. For installation details and complete model numbers, contact the Dynex sales department.

MODEL SELECTION

Clockwise Rotation			Counter-Clockwise Rotation			Shaft (S.A.E. B-B)	Pump Control Description
17.7 U.S. gpm (67,0 L/min) at 1800 rpm	21.5 U.S. gpm (81,4 L/min) at 1800 rpm	24.5 U.S. gpm (92,7 L/min) at 1800 rpm	17.7 U.S. gpm (67,0 L/min) at 1800 rpm	21.5 U.S. gpm (81,4 L/min) at 1800 rpm	24.5 U.S. gpm (92,7 L/min) at 1800 rpm		
PV2024-3084 PV2024-3085	PV2029-3024 PV2029-3026	PV2032-3147 PV2032-3149	PV2024-3086 PV2024-3087	PV2029-3025 PV2029-3027	PV2032-3148 PV2032-3150	Keyed Spline	Pressure Compensated ^①
PV2024-3088 PV2024-3067	PV2029-3028 PV2029-3030	PV2032-3151 PV2032-3153	PV2024-3089 PV2024-3090	PV2029-3029 PV2029-3031	PV2032-3152 PV2032-3154	Keyed Spline	Remote Pressure Compensated ^①
PV2024-2950 PV2024-2951	PV2029-3032 PV2029-3034	PV2032-3155 PV2032-3157	PV2024-3082 PV2024-3083	PV2029-3033 PV2029-3035	PV2032-3156 PV2032-3158	Keyed Spline	Load Sensing ^②
PV2024-3095 PV2024-3096	PV2029-3038 PV2029-3099	— —	PV2024-3097 PV2024-3098	PV2029-3039 PV2029-3100	— —	Keyed Spline	On/Off Control ^②
PV2024-3091 PV2024-3073	PV2029-3036 PV2029-3093	— —	PV2024-3092 PV2024-3074	PV2029-3037 PV2029-3094	— —	Keyed Spline	Modulating Control ^②

① Pressure compensator setting adjustable from 500 to 3000 psi (35 to 210 bar).

② Models listed here also have pressure compensator override.

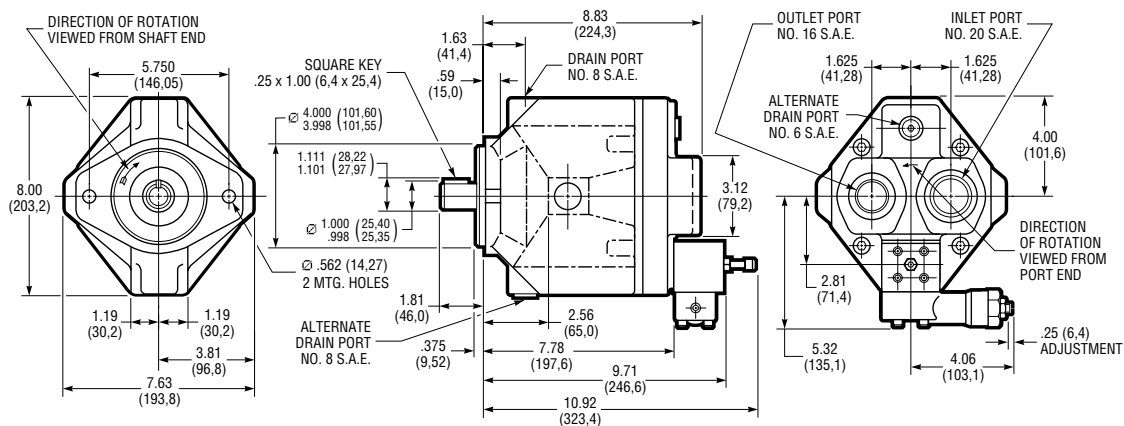

Pressure Compensated Model (With Stroke Limiter)

PV2000 SERIES PUMPS

Installation and Performance Data

Refer to the installation drawing on page 6 for dimensions common to all models.

Standard Seals

Buna-N (Nitrile)

Fluid

High-grade premium petroleum-based oil, with a combination of anti-wear, demulsibility, rust protection, and oxidation resistance and foam resistance properties.

Minimum Filtration Levels

Pump inlet, 25 μ nominal;
Pressure or return line, 25 μ nominal;
Pilot supply (electro-hydraulic models), 10 μ nominal.

While finer filtration levels than these are desirable, restricting flow to the pump inlet must be avoided.

Inlet Conditions (Minimum)

0 psig (0 bar) to 1800 rpm;
5 psig (0,35 bar) to 2800 rpm.

Mounting

Generally, mount pumps with shaft horizontal and either drain port vertically up. Consult your sales representative for other orientations.

Shaft Loading

Consult your Dynex sales representative for applications which require sideloads.

Start-up

Fill pump through upper-most case drain prior to start-up. It may be necessary to bleed air from pump outlet for initial priming.

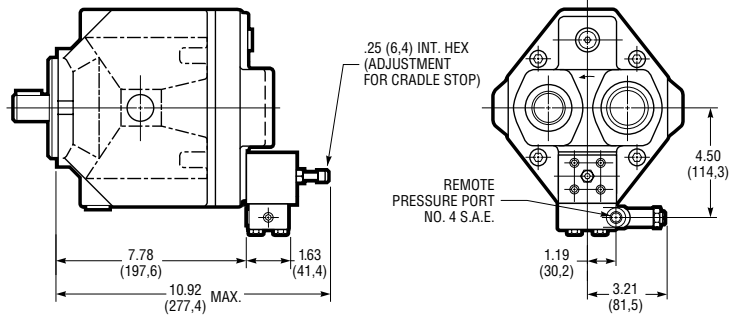

Remote Pressure Compensated Model (With Stroke Limiter)

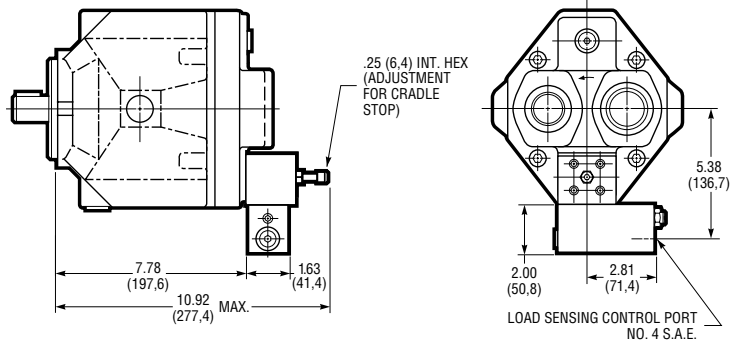

Load Sensing Model (With Stroke Limiter)

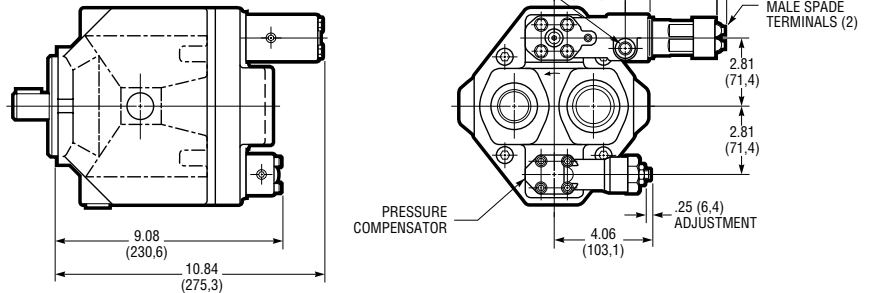

Modulating Model (With Pressure Compensator)

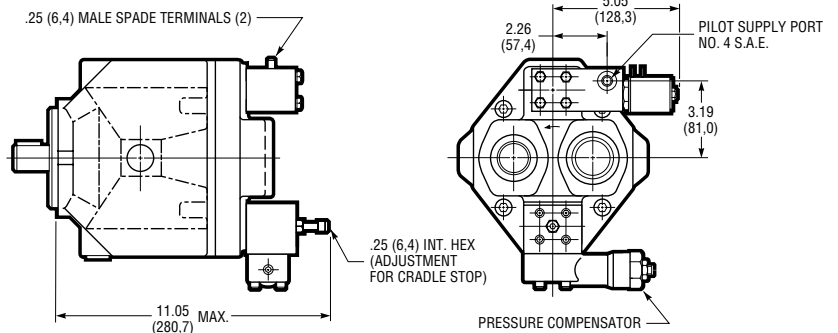

On/Off Model (With Pressure Compensator and Stroke Limiter)

FLUID SPECIFICATIONS^①

Specification	Fluid Grade	
	Summer ^②	Winter ^③
Viscosity at 100° F. (37,8° C)	150-300 SUS (38,3-64,9 cSt)	75-200 SUS (14,4-43,1 cSt)
Viscosity at 210° F. (98,9° C)	43 SUS (5,2 cSt) Minimum	43 SUS (5,2 cSt) Minimum
Pour Point, Typical	0° F. (-17,8° C)	-40° F. (-40° C) or Less
Viscosity Index	95 Minimum	95 Minimum

① If fluid conditions fall outside of the range shown, consult the Dynex sales department.

② Warm Weather Grade, Above +40° F (4,4° C)

③ Cold Weather Grade, Below +40° F (4,4° C)

PV2000 SERIES PUMPS

TYPICAL PERFORMANCE CURVES (AT 1800 RPM)

