

GB
GAS BOOSTERS &
SYSTEMS

AIR DRIVEN GAS BOOSTERS

SC air driven gas boosters are self-contained units, using a cycling spool and pilot valve to provide automatic reciprocating action when air or gas is supplied to the air drive inlet.

The drive consists of a large piston and valve assembly directly connected to a *hydrocarbon-free pumping piston* with self lubricating seals cycling in a stainless barrel that has an integral check valve.

The working surface area of the drive piston exceeds the working surface area of the pump piston, thereby providing the pressure BOOST. This is accomplished by using relatively low pressure air or gas to the drive inlet. The air drive section is pre-lubricated (thus eliminating the need for an air line lubricator), easy to install, and can be mounted in any position eliminating additional floor space. No electrical connections are required.

SC gas boosters are typically used to boost low pressure gas/air to a higher pressure required at the process or test station. Most industrial gases (nitrogen, helium, hydrogen, argon, etc.) are commonly delivered under pressure in steel cylinders. If gas is to be used at low pressures, e.g., welding, the pressurized supply is easily piped and controlled to the point of use with simple valving. However, if the end use requires the gas under pressure, the supply cylinder pressure cannot be utilized after it has fallen to the level of the end use pressure. Therefore, the gas remaining will be wasted unless it is boosted.

If the application requires a pressure greater than the common supply cylinder pressure, a gas booster **must** be used. Depending on the unit selected, you can boost gas pressure from 25 psi and up to 25,000 psi.

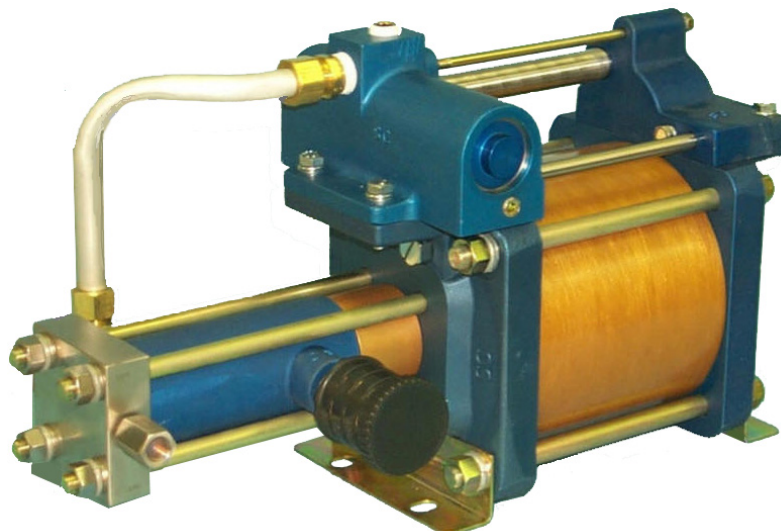

AIR DRIVEN GAS BOOSTERS

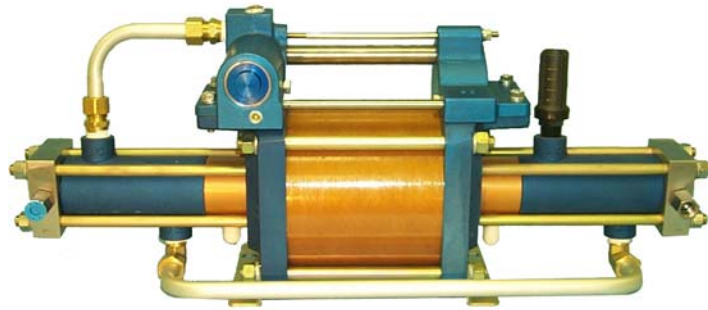

SC gas boosters are suitable for other applications such as bottle filling from nitrogen generators and dewars, hydrogas suspension systems, automotive air gas storage systems, aircraft slide chute gas storage; sulfur hexafluoride (SF₆) transfer for arc suppression and insulation of circuit breakers commonly found in the utility industry, breathing air for scuba diving, gas injection molding, etc.

In addition to our complete line of gas boosters, **SC** also fabricates custom gas booster systems for individual applications. These units are manufactured to customer specifications and can include filters, gauges, pilot switches, panel controls, tubular frames, etc. Contact your distributor or our sales department for more information.

To assist in selecting the best gas booster for your application **SC** offers a free service for sizing units. Just fill out the data worksheet located on page 7 and fax back to us at 714-257-4810 or e-mail the information to service@schydraulic.com. Please make sure to fill out the form completely as all the information is important.



Selecting the Right Booster for Your Application

We could fill several pages of formulas, tables, and explanations of how to determine the best, most economical booster for your application.

After plowing through all the information, including types of gas, decaying supply versus constant, displacement factors, volumetric efficiencies and compression ratios, just to name a few, you may still wonder if you are making the right choice.

At SC Hydraulic Engineering we have a better way -

CALL US!

Or better yet take a minute to read the glossary of terms below so you know the information we need, then fill out the data worksheet on the next page and fax (714-257-4810) or e-mail (service@schydraulic.com) the information to us. We'll have an answer for you within a couple of hours with a selection of boosters, fill times if required, pricing, delivery time, and the name of your nearest distributor.

We figure you have better things to do with your time besides doing our job. For the best service in the industry, call **SC Hydraulic Engineering**.

GLOSSARY OF TERMS

Pa (Air Drive Pressure)

Pressure from air/gas compressor available at the booster to drive the unit. If the pressure fluctuates, the lowest pressure available is used to calculate the output gas pressure. The Pa, and in some selections, along with the supply pressure will determine the maximum stall pressure of the booster.

Va (Air Drive Flow)

Volume of air/gas measured in SCFM (standard cubic feet per minute) available to drive the unit. The volume of air/gas determines the speed in which the booster will cycle and therefore the volume delivered from the outlet port. The volume of outlet gas also determines the speed in which a vessel is filled to a static pressure.

CPM (Air Drive Speed)

Cycles per minute when operating the booster, which is determined by the volume of drive air/gas available. The CPM is highest when starting to fill a vessel and decreases as the output pressure increases until reaching the static or stall pressure.

Ps (Gas Supply Pressure)

Pressure of the gas from the supply source. If the supply is from a gas generator or very large source, the Ps may be considered constant. If from a smaller source, typically bottles, the Ps will decrease as the supply is used. The decrease in supply will affect the static pressure output (in certain boosters) and the fill time or SCFM of the output.

Vs (Gas Supply Volume)

Volume of the gas available from the supply source. This is measured not by SCFM but by ACF (actual cubic feet) or water volume of the source. If the supply is from a gas generator or very large source, the Vs may be considered unlimited. The ACF of the supply determines how many fills to a certain static pressure can be made until the source is depleted.

Po (Gas Outlet Stall Pressure)

Pressure of the gas at the outlet. This can be stated as an output pressure at a certain SCFM or as the static output stall pressure when filling a vessel.

Vo (Gas Outlet Flow)

The volume of gas delivered at the outlet port measured in SCFM. This can be converted to ACFM if the temperature of the output gas is known using the formula: $ACFM = SCFM \times 14.696 / (Pa + 14.696) \times \text{degrees F.} / 530$



DESIGNER AND MANUFACTURER OF HYDRAULIC AND PNEUMATIC EQUIPMENT

SC HYDRAULIC ENGINEERING CORPORATION

1130 Columbia Street, Brea, CA 92821 USA - (714) 257-4800 – Fax (714) 257-4810

DATA WORKSHEET GAS BOOSTER

DATE

CONTACT NAME

CUSTOMER

PHONE

E-MAIL

FAX

CITY

STATE

ZIP

STATE UNITS OF MEASURE USED

PSI

BAR

CU FT

LITER

AIR DRIVE INFORMATION

AIR DRIVE SOURCE:

AIR

PRESSURE MAXIMUM

MINIMUM

NITROGEN

MINIMUM FLOW AVAILABLE TO BOOSTER

SCFM

GAS SUPPLY INLET

TYPE OF GAS

MAXIMUM SUPPLY PRESSURE

MINIMUM

ACTUAL SUPPLY VOLUME

ACF OR

FLOW RATE

SCFM

GAS HIGH PRESSURE OUTLET

OUTLET PRESSURE REQUIRED

TIME REQUESTED TO FILL

ACTUAL VESSEL VOLUME TO FILL

OR FLOW RATE

DIAGRAM OF APPLICATION (optional)

Blank area for diagram of application.

GAS BOOSTER

MODEL SELECTION CHART

Model No.	Maximum Rated Gas Supply (Ps)	Maximum Rated Gas Outlet	Inlet Port Outlet Port	Static Outlet Stall Pressure	Min. Inlet Gas Pressure (Ps) Max. Outlet Gas Pressure (Po)	Maximum Compression Ratio	Displacement Per Stroke (in3 per cycle)
GB-15	2,250 psig 155 bar	2,250 psig 155 bar	1/4" NPT 1/4" NPT	15 Pa	50 psi (3.5 bar) 2,250 psig (155 bar)	20:1	7.05
GB-30	4,500 psig 310 bar	4,500 psig 310 bar	1/4" NPT 1/4" NPT	30 Pa	100 psig (7 bar) 4500 psig (310 bar)	25:1	3.1
GB-75	6,000 psig 410 bar	11,250 psig 775 bar	9/16"-18 ⁽¹⁾ 9/16"-18 ⁽¹⁾	75 Pa	250 psig (17 bar) 11,250 psig (775 bar)	25:1	1.2
GB-D30	6,000 410 bar	9,000 620 bar	1/4" NPT 1/4" NPT	60 Pa	200 psig (13 bar) 9,000 psig (620 bar)	25:1	3.1
GB-D75	6,000 410 bar	20,000 psig 1,380 bar	9/16"-18 ⁽¹⁾ 9/16"-18 ⁽¹⁾	150 Pa	250 psig (17 bar) 20,000 psig (1,380 bar)	25:1	1.2
GBD-5	1500 psig 103 bar	1500 103 bar	1/2" NPT 1/2" NPT	4.7 Pa +Ps	25 psig 1500 psig	10:1	28.2
GBD-15	5,000 psig 345 bar	5,000 psig 345 bar	1/4" NPT 1/4" NPT	15 Pa + Ps	50 psi (3.5 bar) 5,000 psig (345 bar)	20:1	14.1
GBD-30	6,000 psig 410 bar	9,000 psig 620 bar	1/4" NPT 1/4" NPT	30 Pa + Ps	100 psig (7 bar) 9,000 psig (620 bar)	25:1	6.3
GBD-75	6,000 psig 410 bar	20,000 psig 1,380 bar	9/16"-18 ⁽¹⁾ 9/16"-18 ⁽¹⁾	75 Pa + Ps	250 psig (17 bar) 20,000 psig (1,380 bar)	25:1	2.4
GBD-D15	5,000 psig 345 bar	5,000 psig 345 bar	1/4" NPT 1/4" NPT	30 Pa + Ps	50 psi (3.5 bar) 5,000 psig (345 bar)	20:1	14.1
GBD-D30	6,000 psig 410 bar	9,000 psig 620 bar	1/4" NPT 1/4" NPT	60 Pa + Ps	200 psig (14 bar) 9,000 psig (620 bar)	25:1	6.3
GBD-D75	6,000 psig 410 bar	25,000 psig 1,725 bar	9/16"-18 ⁽¹⁾ 9/16"-18 ⁽¹⁾	150 Pa + Ps	250 psig (17 bar) 25,000 psig (1,725 bar)	25:1	2.4
GBT-15/30	15 Pa to 2,500 psig ⁽²⁾ 172 bar	9,000 psig 620 bar	1/4" NPT 1/4" NPT	30 Pa +2 Ps	50 psi (3.5 bar) 8,500 psig (586 bar)	50:1	7.05
GBT-15/75	3.5 Pa to 5,000 psig ⁽²⁾ 345 bar	20,000 psig 1,380 bar	9/16"-18 ⁽¹⁾ 9/16"-18 ⁽¹⁾	75 Pa + 5 Ps	50 psi (3.5 bar) 13,000 psig	100:1	7.05
GBT-30/75	20 Pa to 6,000 psig ⁽²⁾ 410 bar	20,000 psig 1,380 bar	9/16"-18 ⁽¹⁾ 9/16"-18 ⁽¹⁾	75 Pa + 2.5 Ps	100 psig (7 bar) 16,000 psig (1103 bar)	60:1	3.1
GBT-D15/30	30 Pa to 2,500 psig ⁽²⁾ 172 bar	9,000 psig 620 bar	1/4" NPT 1/4" NPT	60 Pa +2 Ps	100 psig (7 bar) 9,000 psig (620 bar)	50:1	7.05
GBT-D15/75	7 Pa to 5,000 psig ⁽²⁾ 345 bar	25,000 psig 1,725 bar	9/16"-18 ⁽¹⁾ 9/16"-18 ⁽¹⁾	150 Pa + 5 Ps	100 psig (7 bar) 25,000 psig (1,725 bar)	100:1	6.3
GBT-D30/75	40 Pa to 3,600 psig ⁽²⁾ 245 bar	25,000 psig 1,725 bar	9/16"-18 ⁽¹⁾ 9/16"-18 ⁽¹⁾	150 Pa + 2.5 Ps	100 psig (7 bar) 25,000 psig (1,725 bar)	60:1	3.1

(1) Coned and threaded high pressure connection for 1/4" O.D. tubing

(2) In order to prevent interstage stall, limit supply pressure air drive pressure (Pa) times the formula factor

Legend

Pa = Drive Pressure
(150 psig maximum)
Ps = Gas Inlet Pressure
Po = Gas Outlet Pressure

GB SERIES

Single Stage-Single Acting Booster

The GB series is the most economical of the SC Hydraulic Gas Boosters and is ideal for applications not requiring much volume such as pressure testing small vessels or components. Pressures can be boosted from as low as 50 psig and up to over 11,000 psig.

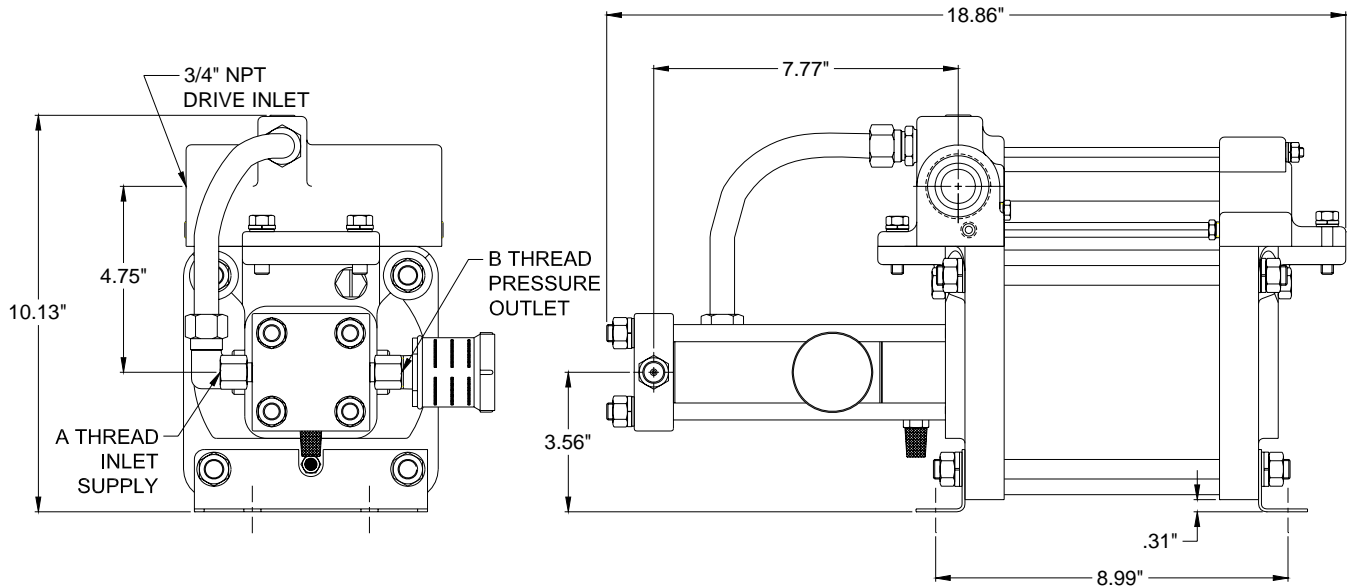

Model No.	Maximum Rated Gas Supply (Ps)	Maximum Rated Gas Outlet (Po)	A Inlet Port B Outlet Port	Static Outlet Stall Pressure	Min. Inlet Gas Pressure (Ps) Max. Outlet Gas Pressure (Po)	Maximum Compression Ratio	Displacement Per Stroke (in3 per cycle)
GB-15	2,250 psig 155 bar	2,250 psig 155 bar	1/4" NPT 1/4" NPT	15 Pa	50 psig (3.5 bar) 2,250 psig (155 bar)	20:1	7.05
GB-30	4,500 psig 310 bar	4,500 psig 310 bar	1/4" NPT 1/4" NPT	30 Pa	100 psig (7 bar) 4500 psig (310 bar)	25:1	3.1
GB-75	6,000 psig 410 bar	11,250 psig 775 bar	9/16"-18 ⁽¹⁾ 9/16"-18 ⁽¹⁾	75 Pa	250 psig (17 bar) 11,250 psig (775 bar)	25:1	1.2

(1) Coned and Threaded High Pressure Connection for 1/4" O.D. Tubing

For assistance in selecting the proper Gas Booster complete and fax the data work sheet at the end of the catalog or e-mail inquires to service@schydraulic.com

GB SERIES

Single Stage-Single Acting Booster

GB-15

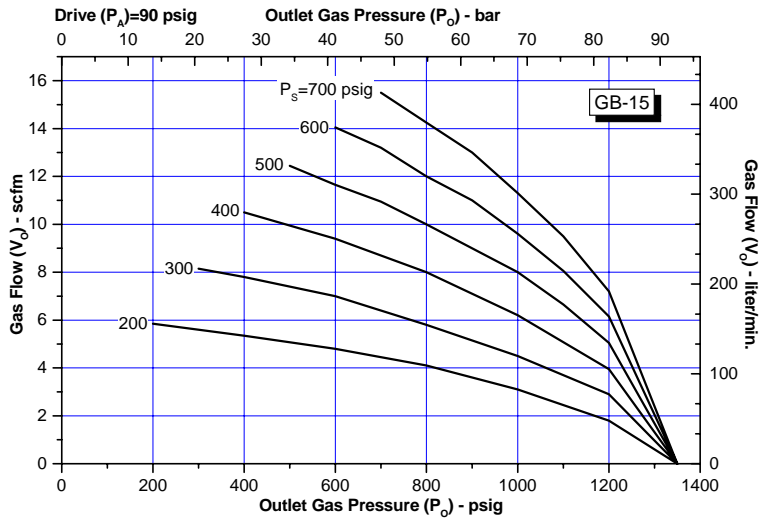

Legend

PA = Drive Pressure
(150 psig maximum)
PO = Gas Outlet Pressure
PS = Gas Inlet Pressure
VO = Output Gas Flow

NOTE:
Performance charts are for reference only.

The curves are based on an Air Drive (P_a) of 90 psig. If the P_a is higher (up to 150 psig) or lower, the Outlet gas pressure (P_o) can change significantly.

Also, the supply pressures (P_s) shown in the graphs are based on constant pressure being supplied as the pressure is boosted. A supply from cylinders or bottles will affect the pressure outlet (P_o) and flow (V_o) as the supply pressure (P_s) is depleted.

Contact SC Hydraulic Engineering for detailed performance data on any particular application.

GB-30

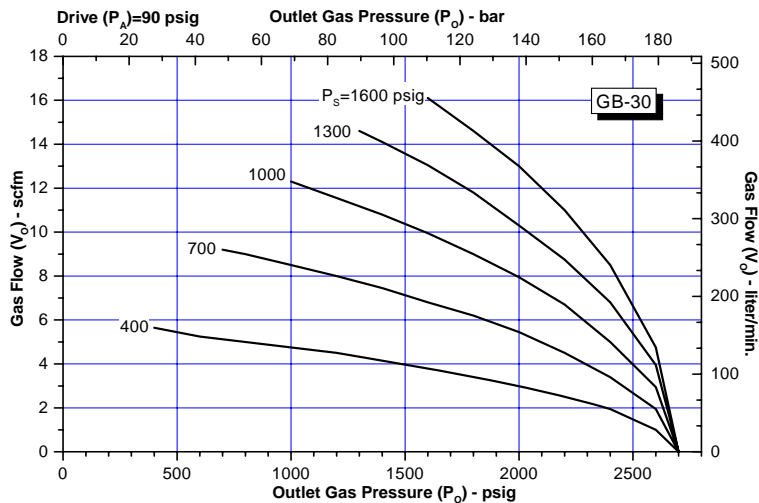

GB-75

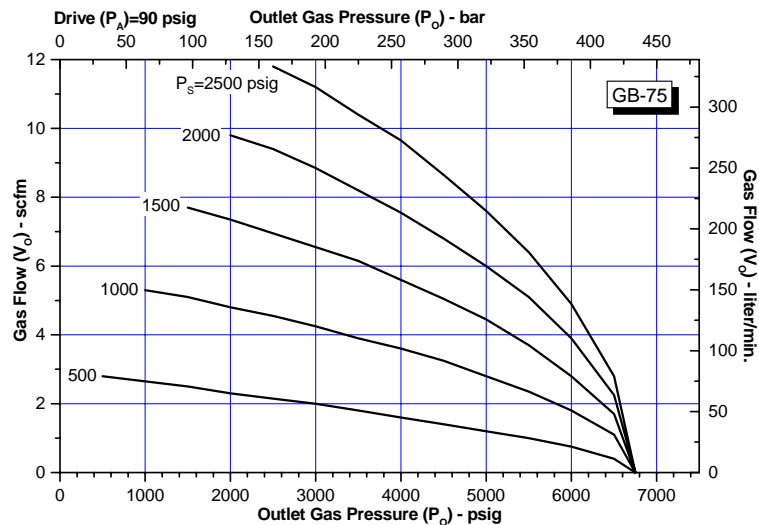

GB-D SERIES

Single Stage-Single Acting Double Head Booster

This series has the same characteristics of the standard GB Series however the double head allows half the input pressure to achieve the same outlet pressure.

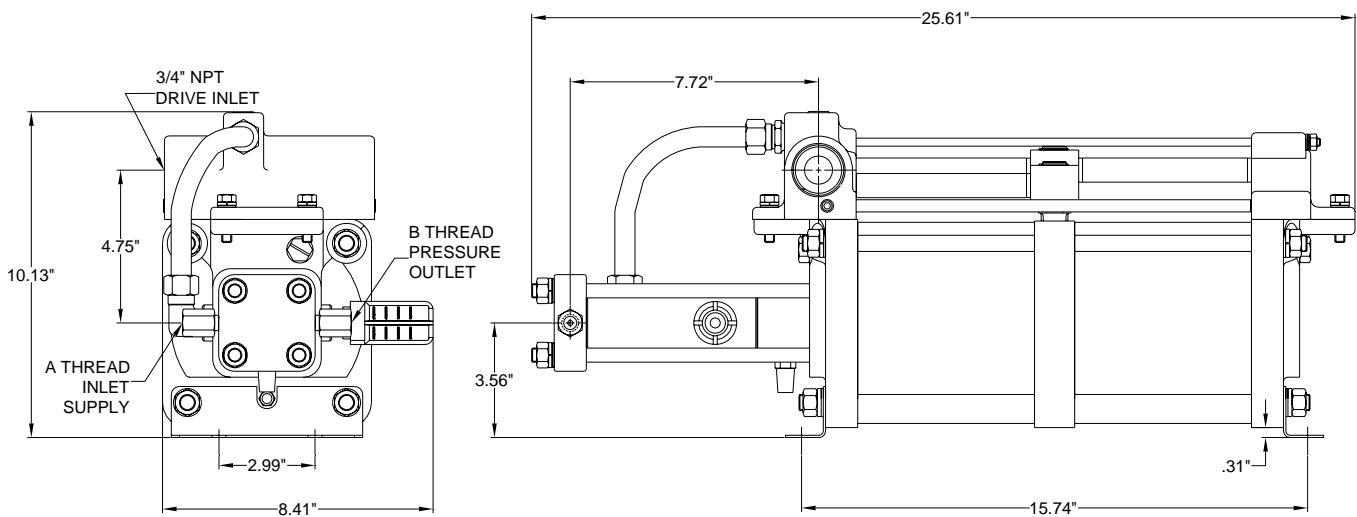

Model No.	Maximum Rated Gas Supply (Ps)	Maximum Rated Gas Outlet	Inlet Port Outlet Port	Static Outlet Stall Pressure	Min. Inlet Gas Pressure (Ps) Max. Outlet Gas Pressure (Po)	Maximum Compression Ratio	Displacement Per Stroke (in ³ per cycle)
GB-D30	6,000 410 bar	9,000 620 bar	1/4" NPT 1/4" NPT	60 Pa	200 psig (13 bar) 9,000 psig (620 bar)	25:1	3.1
GB-D75	6,000 410 bar	20,000 psig 1,380 bar	9/16"-18 ⁽¹⁾ 9/16"-18 ⁽¹⁾	150 Pa	250 psig (17 bar) 20,000 psig (1,380 bar)	25:1	1.2

(1) Coned and threaded high pressure connection for 1/4" O.D. tubing

For assistance in selecting the proper Gas Booster complete and fax the data work sheet at the end of the catalog or e-mail inquires to service@schydraulic.com

GB-D SERIES

Single Stage-Single Acting Double Head Booster

GB-D15

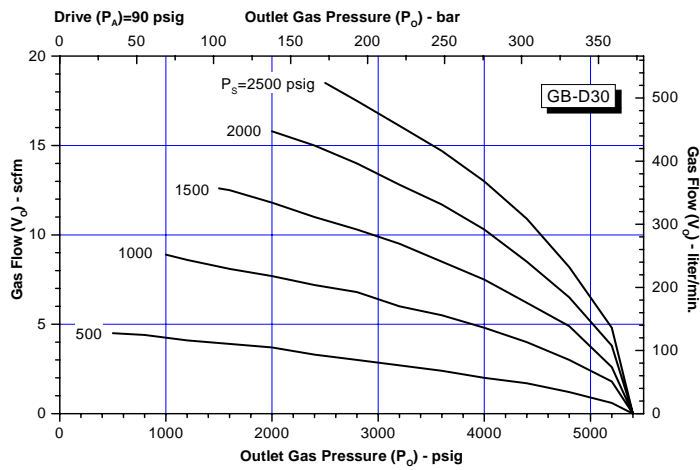

Legend

PA = Drive Pressure
(150 psig maximum)
PO = Gas Outlet Pressure
PS = Gas Inlet Pressure
VO = Output Gas Flow

NOTE:

Performance charts are for reference only.

The curves are based on an Air Drive (P_a) of 90 psig. If the P_a is higher (up to 150 psig) or lower, the Outlet gas pressure (P_o) can change significantly.

Also, the supply pressures (P_s) shown in the graphs are based on constant pressure being supplied as the pressure is boosted. A supply from cylinders or bottles will affect the pressure outlet (P_o) and flow (V_o) as the supply pressure (P_s) is depleted.

Contact SC Hydraulic Engineering for detailed performance data on any particular application.

GB-D75

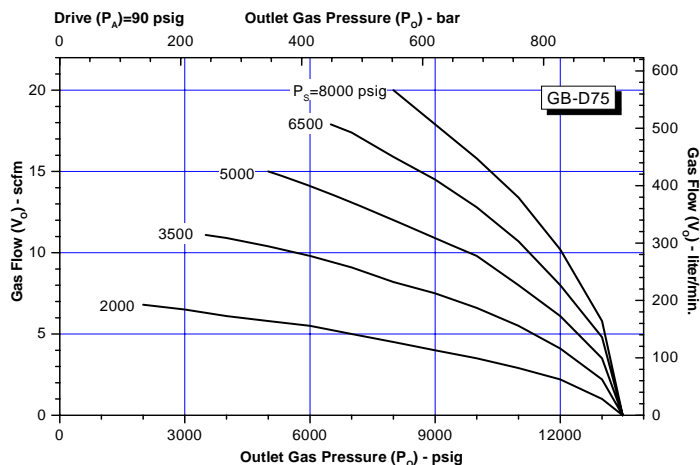

GBD-5

Single Stage-Double Acting Booster

This gas booster is a modified version of our popular ABD air booster. It is used to boost gas pressures up to 1,500 psig. The booster is able to move large volumes of gas efficiently when lower pressures are suitable. For convenience, the graph illustrates various inlet gas supplies with matching air drive pressures.

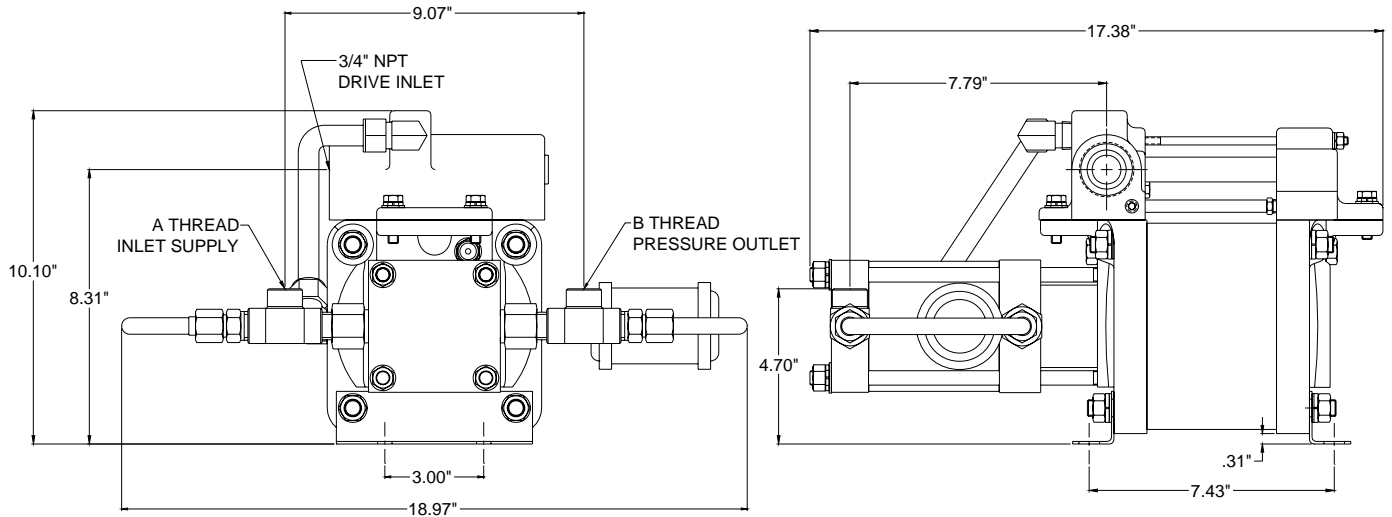

Model No.	Maximum Rated Gas Supply (Ps)	Maximum Rated Gas Outlet	Inlet Port Outlet Port	Static Outlet Stall Pressure	Min. Inlet Gas Pressure (Ps) Max. Outlet Gas Pressure (Po)	Maximum Compression Ratio	Displacement Per Stroke (in3 per cycle)
GBD-5	1500 psig 103 bar	1500 103 bar	1/2" NPT 1/2" NPT	4.7 Pa +Ps	25 psig 1500 psig	10:1	28.2

Legend
 PA = Drive Pressure
 (150 psig maximum)
 PO = Gas Outlet Pressure
 PS = Gas Inlet Pressure
 VO = Output Gas Flow

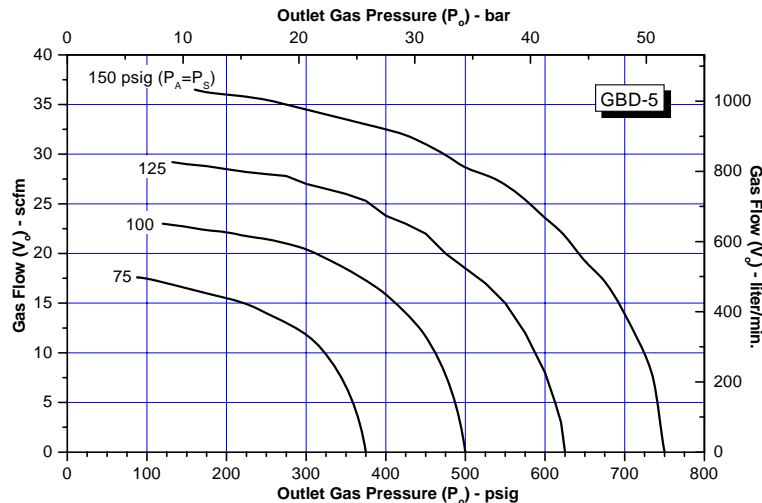

GBD-5

See **NOTE** on previous page regarding Performance Charts

For assistance in selecting the proper Gas Booster complete and fax the data work sheet at the end of the catalog or e-mail inquires to service@schydraulic.com

GBD SERIES

Single Stage-Double Acting Booster

This series of boosters doubles the volume of output gas per cycle and is a good choice for moving relatively high volumes at pressures up to 20,000 psig. Supply pressure is added to the maximum outlet pressure.

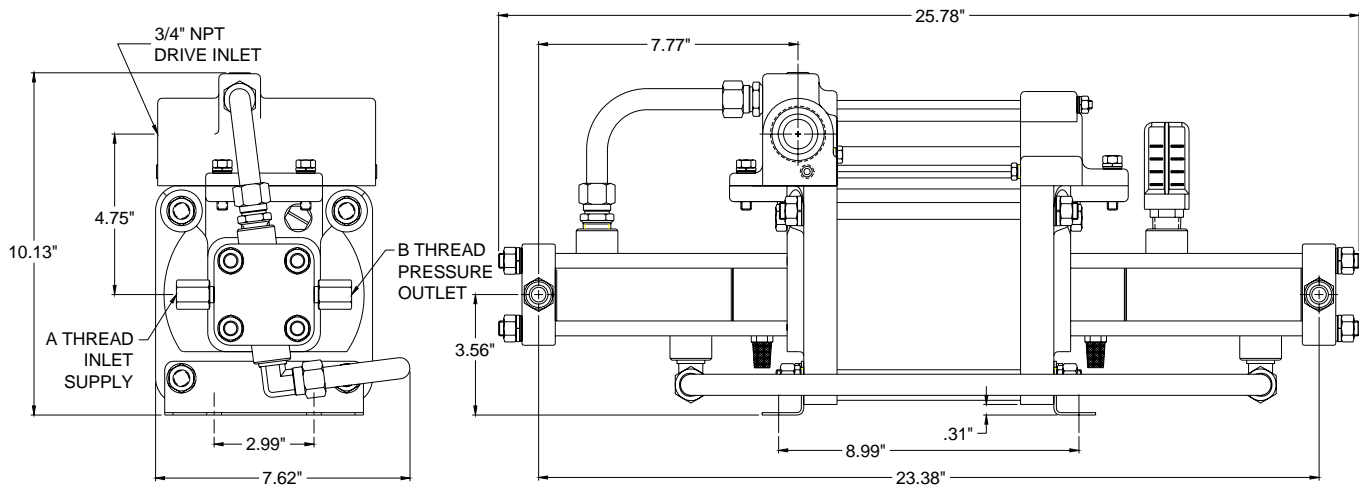

Model No.	Maximum Rated Gas Supply (Ps)	Maximum Rated Gas Outlet (Po)	A Inlet Port B Outlet Port	Static Outlet Stall Pressure	Min. Inlet Gas Pressure (Ps) Max. Outlet Gas Pressure (Po)	Maximum Compression Ratio	Displacement Per Stroke (in ³ per cycle)
GBD-15	5,000 psig 345 bar	5,000 psig 345 bar	1/4" NPT 1/4" NPT	15 Pa + Ps	50 psig (3.5 bar) 5,000 psig (345 bar)	20:1	14.1
GBD-30	6,000 psig 410 bar	9,000 psig 620 bar	1/4" NPT 1/4" NPT	30 Pa + Ps	100 psig (7 bar) 9,000 psig (620 bar)	25:1	6.3
GBD-75	6,000 psig 410 bar	20,000 psig 1,380 bar	9/16"-18 ⁽¹⁾ 9/16"-18 ⁽¹⁾	75 Pa + Ps	250 psig (17 bar) 20,000 psig (1,380 bar)	25:1	2.4

(1) Coned and Threaded High Pressure Connection for 1/4" O.D. Tubing

For assistance in selecting the proper Gas Booster complete and fax the data work sheet at the end of the catalog or e-mail inquires to service@schydraulic.com

GBD SERIES

Single Stage-Double Acting Booster

Legend
 PA = Drive Pressure
 (150 psig maximum)
 PO = Gas Outlet Pressure
 PS = Gas Inlet Pressure
 VO = Output Gas Flow

NOTE:
 Performance charts are for reference only.

The curves are based on an Air Drive (Pa) of 90 psig. If the Pa is higher (up to 150 psig) or lower, the Outlet gas pressure (Po) can change significantly.

Also, the supply pressures (Ps) shown in the graphs are based on constant pressure being supplied as the pressure is boosted. A supply from cylinders or bottles will affect the pressure outlet (Po) and flow (Vo) as the supply pressure (Ps) is depleted.

Contact SC Hydraulic Engineering for detailed performance data on any particular application.

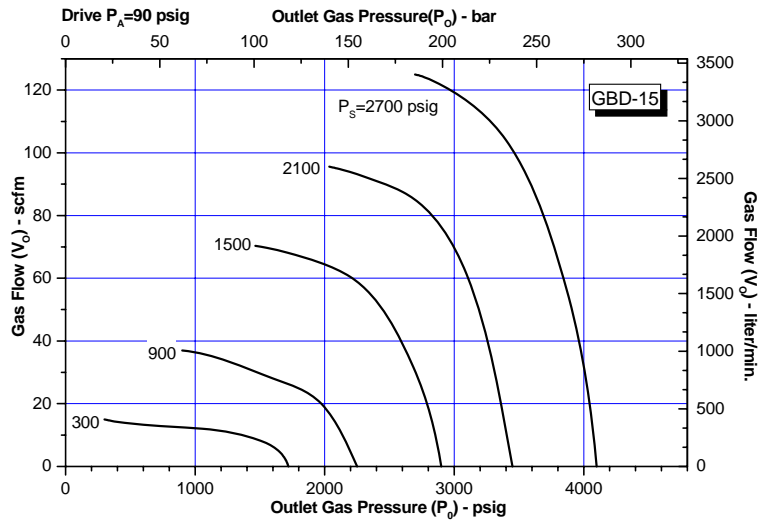

GBD-15

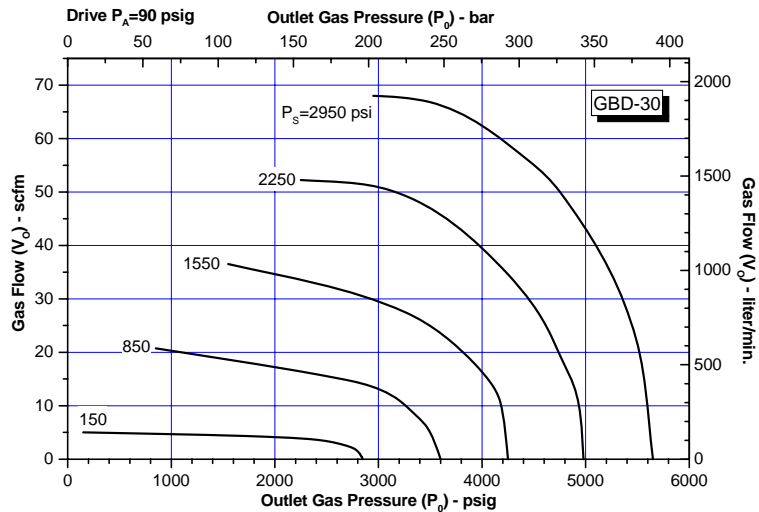

GBD-30

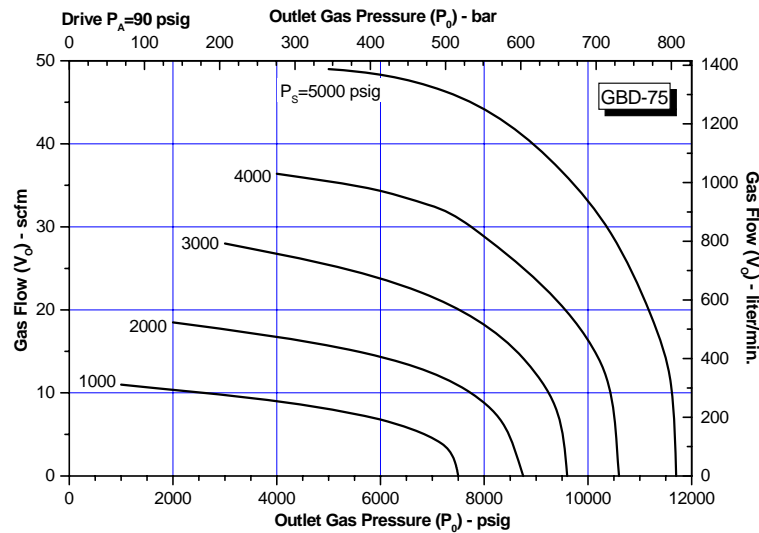

GBD-75

GBD-D SERIES

Double Acting-Double Head Booster

This series has the same characteristics of the standard GBD however the double head allows half the input pressure to achieve the same outlet pressure.

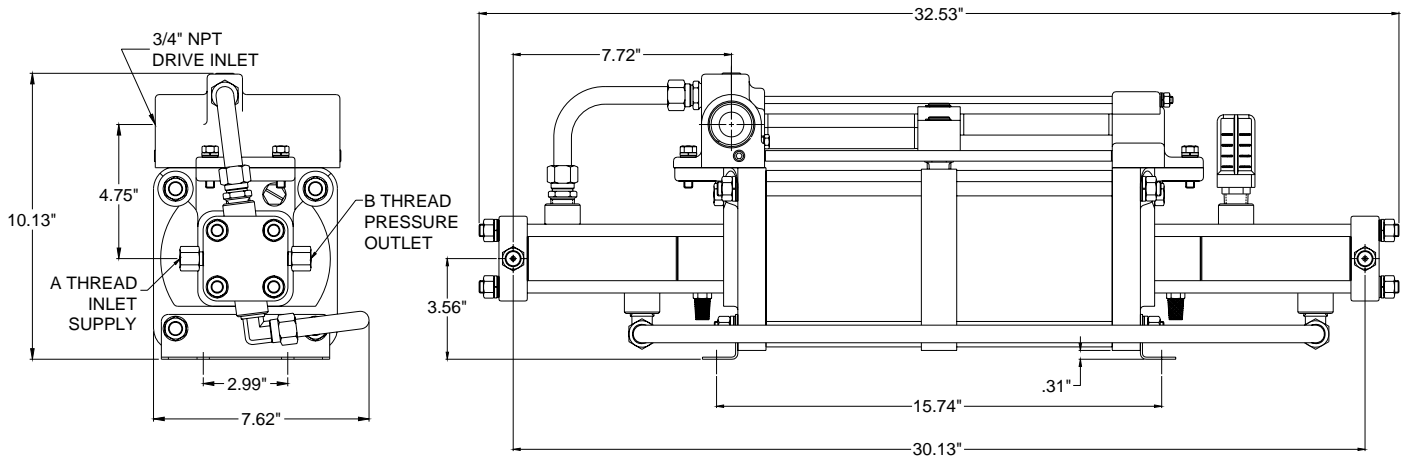

Model No.	Maximum Rated Gas Supply (Ps)	Maximum Rated Gas Outlet (Po)	Inlet Port Outlet Port	Static Outlet Stall Pressure	Min. Inlet Gas Pressure (Ps) Max. Outlet Gas Pressure (Po)	Maximum Compression Ratio	Displacement Per Stroke (in ³ per cycle)
GBD-D15	5,000 psig 345 bar	5,000 psig 345 bar	1/4" NPT 1/4" NPT	30 Pa + Ps	50 psig (3.5 bar) 5,000 psig (345 bar)	20:1	14.1
GBD-D30	6,000 psig 410 bar	9,000 psig 620 bar	1/4" NPT 1/4" NPT	60 Pa + Ps	200 psig (14 bar) 9,000 psig (620 bar)	25:1	6.3
GBD-D75	6,000 psig 410 bar	25,000 psig 1,725 bar	9/16"-18 ⁽¹⁾ 9/16"-18 ⁽¹⁾	150 Pa + Ps	250 psig (17 bar) 25,000 psig (1,725 bar)	25:1	2.4

(1) Coned and Threaded High Pressure Connection for 1/4" O.D. Tubing

For assistance in selecting the proper Gas Booster complete and fax the data work sheet at the end of the catalog or e-mail inquires to service@schydraulic.com

GBD-D SERIES

Double Acting-Double Head Booster

Legend
 PA = Drive Pressure
 (150 psig maximum)
 PO = Gas Outlet Pressure
 PS = Gas Inlet Pressure
 VO = Output Gas Flow

NOTE:
 Performance charts are for reference only.

The curves are based on an Air Drive (Pa) of 90 psig. If the Pa is higher (up to 150 psig) or lower, the Outlet gas pressure (Po) can change significantly.

Also, the supply pressures (Ps) shown in the graphs are based on constant pressure being supplied as the pressure is boosted. A supply from cylinders or bottles will affect the pressure outlet (Po) and flow (Vo) as the supply pressure (Ps) is depleted.

Contact SC Hydraulic Engineering for detailed performance data on any particular application

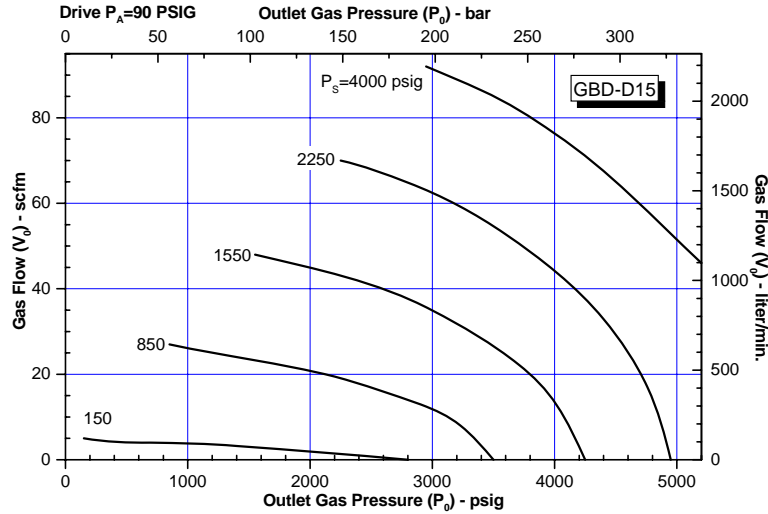

GBD-D15

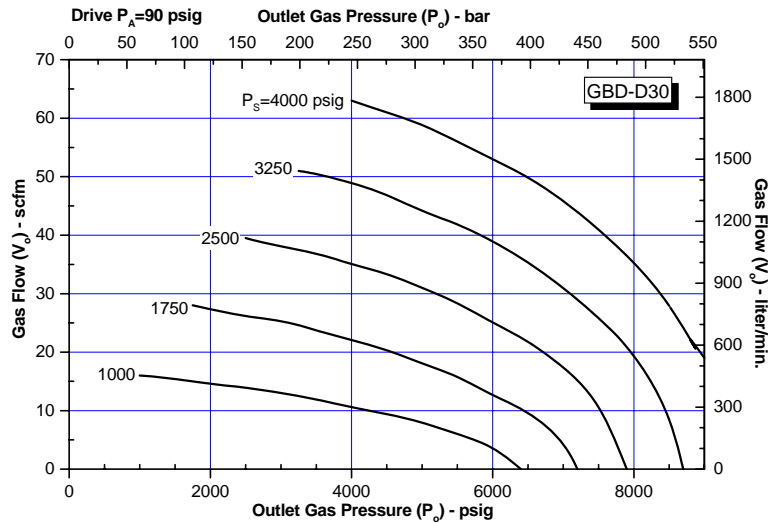

GBD-D30

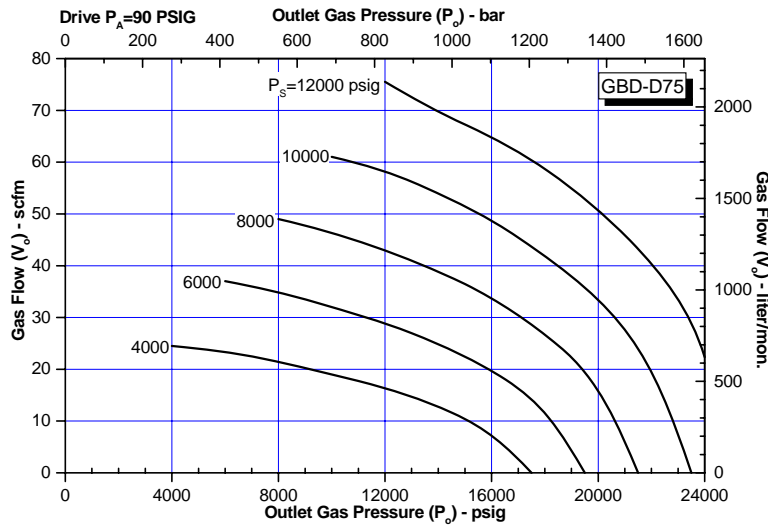

GBD-D75

GBT SERIES

Two Stage-Double Acting Booster

The GBT series is able to achieve higher compression ratios by combining the first and second stage with an interconnected hydraulic (gas) piston. Maximum outlet pressure is the supply pressure plus the drive area ratio times the area ratio of both hydraulic (gas) pistons.

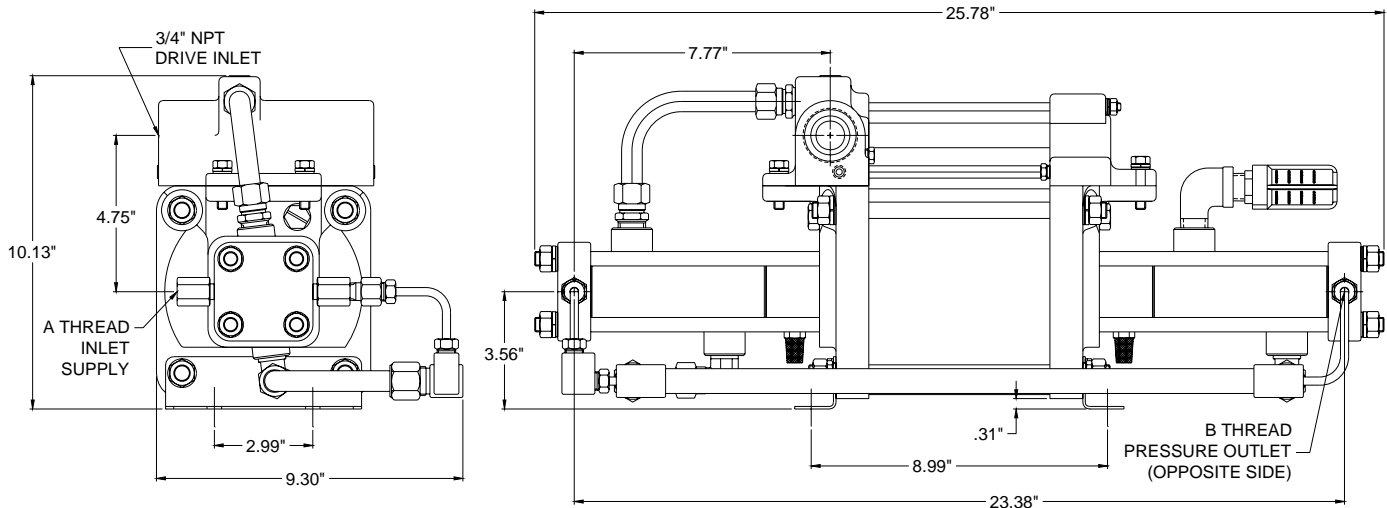

Model No.	Maximum Rated Gas Supply (Ps)	Maximum Rated Gas Outlet (Po)	Inlet Port Outlet Port	Static Outlet Stall Pressure	Min. Inlet Gas Pressure (Ps) Max. Outlet Gas Pressure (Po)	Maximum Compression Ratio	Displacement Per Stroke (in ³ per cycle)
GBT-15/30	15 Pa to 2,500 psig ⁽²⁾ 172 bar	9,000 psig 620 bar	1/4" NPT 1/4" NPT	30 Pa +2 Ps	50 psig (3.5 bar) 8,500 psig (586 bar)	50:1	7.05
GBT-15/75	3.5 Pa to 5,000 psig ⁽²⁾ 345 bar	20,000 psig 1,380 bar	1/4" NPT 9/16"-18 ⁽¹⁾	75 Pa + 5 Ps	50 psig (3.5 bar) 13,000 psig (896 bar)	100:1	7.05
GBT-30/75	20 Pa to 6,000 psig ⁽²⁾ 410 bar	20,000 psig 1,380 bar	1/4" NPT 9/16"-18 ⁽¹⁾	75 Pa + 2.5 Ps	100 psig (7 bar) 16,000 psig (1103 bar)	60:1	3.1

(1) Coned and threaded high pressure connection for 1/4" O.D. tubing

(2) In order to prevent interstage stall, limit supply pressure air drive pressure (Pa) times the formula factor

For assistance in selecting the proper Gas Booster complete and fax the data work sheet at the end of the catalog or e-mail inquires to service@schydraulic.com

GBT SERIES

Two Stage-Double Acting Booster

Legend
 PA = Drive Pressure
 (150 psig maximum)
 PO = Gas Outlet Pressure
 PS = Gas Inlet Pressure
 VO = Output Gas Flow

NOTE:
 Performance charts are for reference only.

The curves are based on an Air Drive (Pa) of 90 psig. If the Pa is higher (up to 150 psig) or lower, the Outlet gas pressure (Po) and flow (Vo) as the supply pressure (Ps) is depleted.

Also, the supply pressures (Ps) shown in the graphs are based on constant pressure being supplied as the pressure is boosted. A supply from cylinders or bottles will affect the pressure outlet (Po) and flow (Vo) as the supply pressure (Ps) is depleted.

Contact SC Hydraulic Engineering for detailed performance data on any particular application.

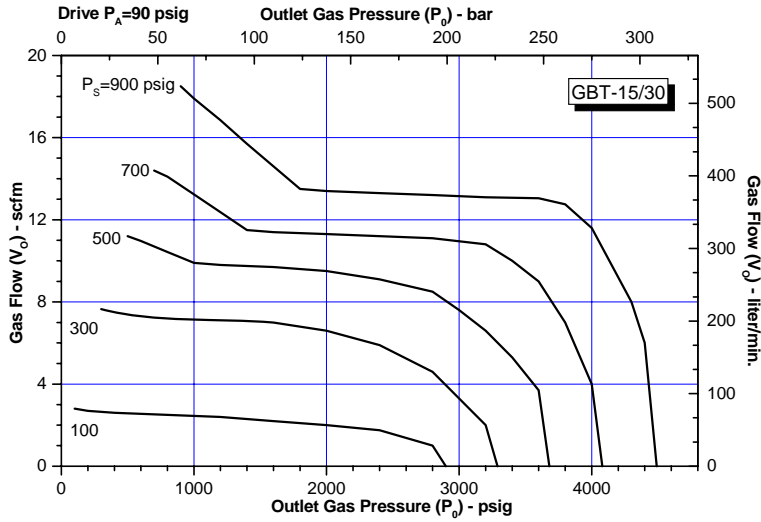

GBT-15/30

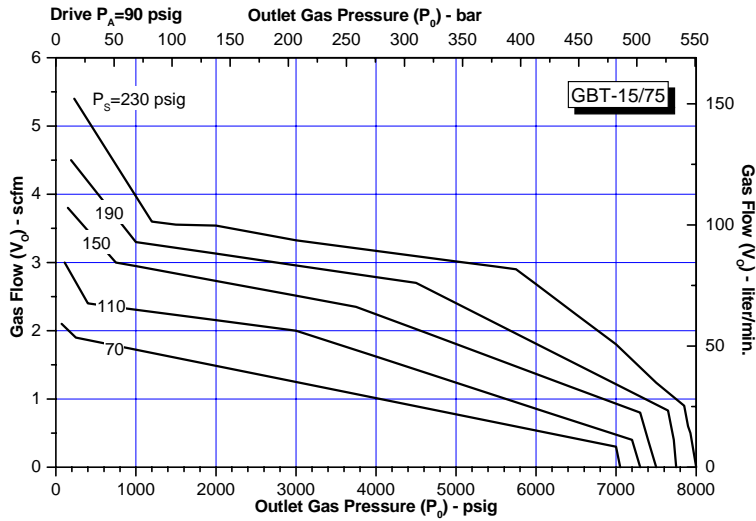

GBT-15/75

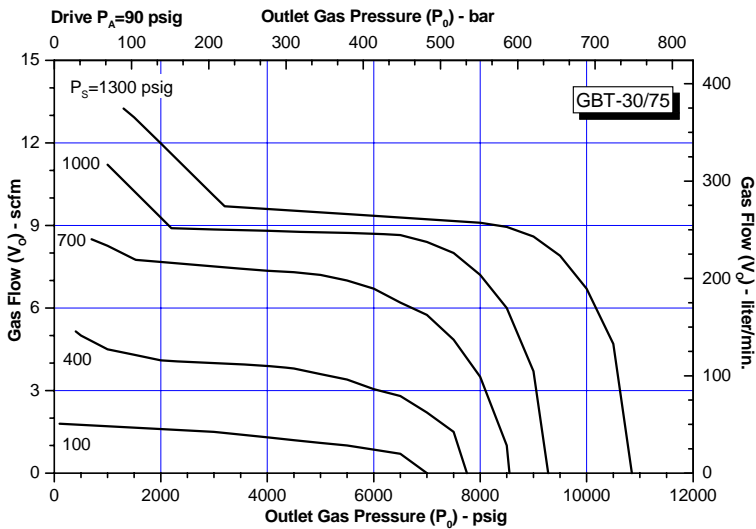

GBT-30/75

GBT-D SERIES

Two Stage-Double Head Booster

This series has the same characteristics of the standard GBT however the double head allows half the input pressure to achieve the same outlet pressure.

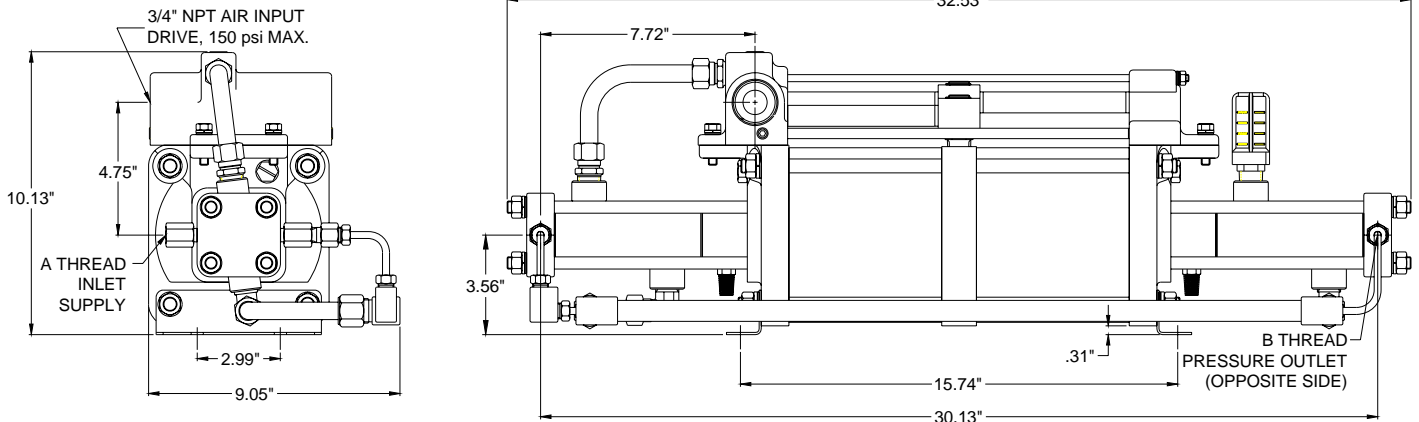

Model No.	Maximum Rated Gas Supply (Ps)	Maximum Rated Gas Outlet (Po)	Inlet Port Outlet Port	Static Outlet Stall Pressure	Min. Inlet Gas Pressure (Ps) Max. Outlet Gas Pressure (Po)	Maximum Compression Ratio	Displacement Per Stroke (in ³ per cycle)
GBT-D15/30	30 Pa to 2,500 psig ⁽²⁾ 172 bar	9,000 psig 620 bar	1/4" NPT 1/4" NPT	60 Pa + 2 Ps	100 psig (7 bar) 9,000 psig (620 bar)	50:1	7.05
GBT-D15/75	7 Pa to 5,000 psig ⁽²⁾ 345 bar	25,000 psig 1,725 bar	1/4" NPT 9/16"-18 ⁽¹⁾	150 Pa + 5 Ps	100 psig (7 bar) 25,000 psig (1,725 bar)	100:1	7.05
GBT-D30/75	40 Pa to 6,000 psig ⁽²⁾ 410 bar	25,000 psig 1,725 bar	1/4" NPT 9/16"-18 ⁽¹⁾	150 Pa + 2.5 Ps	100 psig (7 bar) 25,000 psig (1,725 bar)	60:1	3.1

(1) Coned and threaded high pressure connection for 1/4" O.D. tubing

(2) In order to prevent interstage stall, limit supply pressure air drive pressure (Pa) times the formula factor

For assistance in selecting the proper Gas Booster complete and fax the data work sheet at the end of the catalog or e-mail inquires to service@schaudraulic.com

GBT-D SERIES

Two Stage-Double Head Booster

Legend
 PA = Drive Pressure
 (150 psig maximum)
 PO = Gas Outlet Pressure
 PS = Gas Inlet Pressure
 VO = Output Gas Flow

NOTE:
 Performance charts are for reference only.

The curves are based on an Air Drive (Pa) of 90 psig. If the Pa is higher (up to 150 psig) or lower, the Outlet gas pressure (Po) can change significantly.

Also, the supply pressures (Ps) shown in the graphs are based on constant pressure being supplied as the pressure is boosted. A supply from cylinders or bottles will affect the pressure outlet (Po) and flow (Vo) as the supply pressure (Ps) is depleted.

Contact SC Hydraulic Engineering for detailed performance data on any particular application.

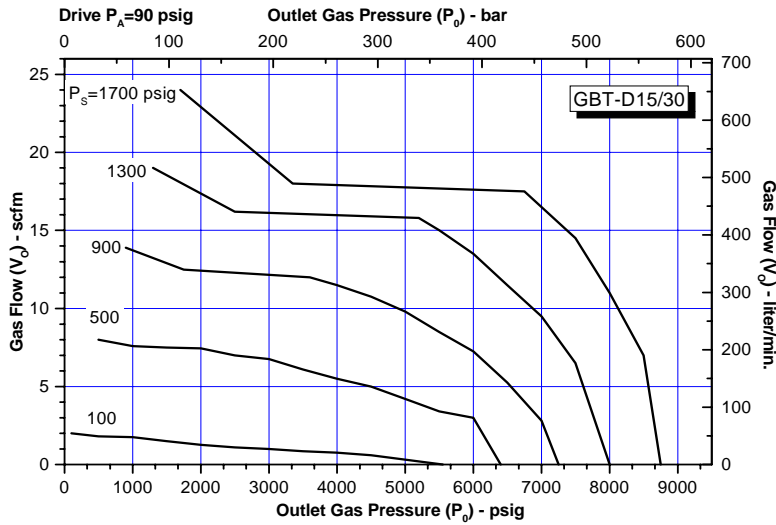

GBT-D15/30

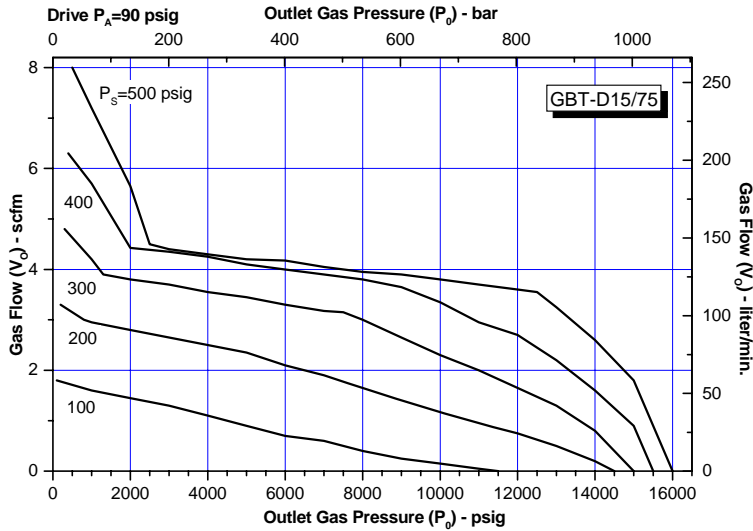

GBT-D15/75

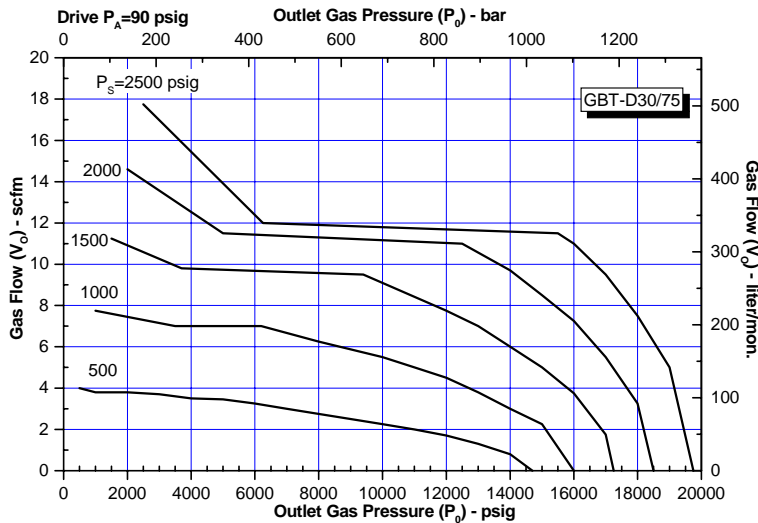

GBT-D30/75

HOW TO ORDER TABLE

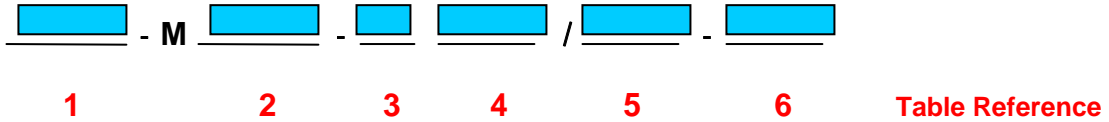

Example #1 Pump Selection GB-15-O2

GB Series Single Stage

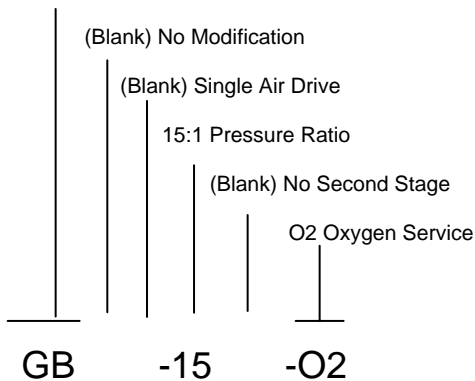

Example #2 Pump Selection GBT-M402-D 30/75

GBT Two Stage-Double Acting

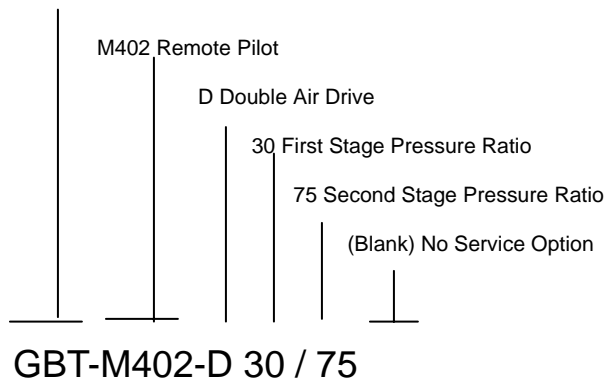

TABLE 1 ⁽¹⁾ Gas Booster Series

GB	Single Stage
GBD	Single Stage Double Acting
GBT	Two Stage Double Acting

TABLE 2 Modification

Blank	No Modification
401	No Inlet/No Outlet Plumbing ⁽²⁾
402	Remote Pilot
403	Plumbing for Single Inlet/Outlet ⁽³⁾

TABLE 3 Cylinder Modification

Blank	Single Head
D	Double Head

TABLE 4 Pressure Ratio Single or First Stage

5	GB, GBD, GBT
15	GB, GBD, GBT
30	GB, GBD, GBT
75	GB, GBD, GBT

TABLE 5 Pressure Ratio Second Stage

Blank	
30	GBT
75	GBT

TABLE 6 Service Option

Blank	Standard
O2	Oxygen Service
H2	Hydrogen Service

Notes:

- (1) Do not fill gap on a two digit description.
- (2) Available on GBD-5 only
- (3) Available on GBD, GBD-D only

GAS BOOSTER SYSTEMS

Standard or Custom

SC Hydraulic Engineering Corporation builds every booster system like it's a custom unit built just for you. What separates us from other manufacturers is how fast we can ship you a complete system, whether it is considered a standard or in fact is a custom unit.

Our standard delivery for a complete system is one to two weeks, even quicker if you're willing to pay a nominal expedite fee. Better yet, a custom unit i.e. multiple boosters, extra ports, special valves, etc. is typically 3-4 week delivery. In most cases our deliveries are only extended if we have to wait for customer supplied add-on parts.



Our 3-4 week delivery for specials is about half the time other manufacturers' quote for a **standard** booster system!

We are able to do this because it is all we do. Our gas booster department builds only gas boosters and gas booster systems. The size of our company (we're proud of the fact we are not the largest) gives us the ability to be extremely flexible and work with each customer as an individual, not part of the herd.

Plus most of our manufactured parts are produced in house on state-of-the-art equipment. We are never dependent on some supplier's missed delivery, hence backing up all the orders in-house.

Our standard booster systems are built in three categories depending on the maximum outlet pressure a unit can deliver, 6K, 20K, or 25K PSI. Virtually any booster we manufacture can be used in a system.

Standard items on the booster are inlet air and gas supply filter, panel mounted air shut-off, regulator, air drive, gas supply and outlet gauges, and relief valve.

Bulkhead connections for air supply, gas supply and gas outlet are mounted on the side of the tubular frame. Standard frames are 38" or 45" long depending on the booster model.

Standard options are outlet filter, automatic start and/ or stop pilot switches, hydrogen, or oxygen service.

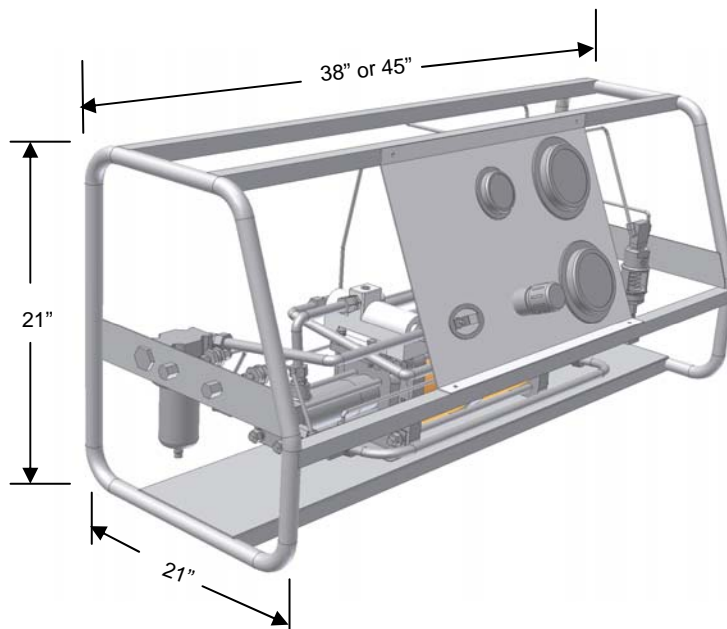

Typical Gas Booster System Layout

HOW TO ORDER TABLE

STANDARD GAS BOOSTER SYSTEMS

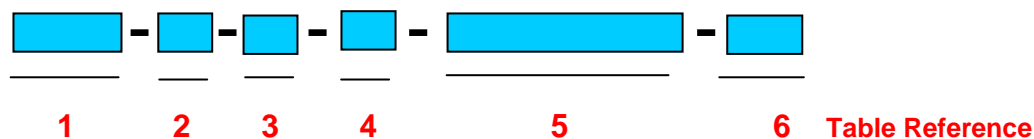

Example #1 Gas Booster System Selection

Tubular Frame System for pressure to 6000 psi

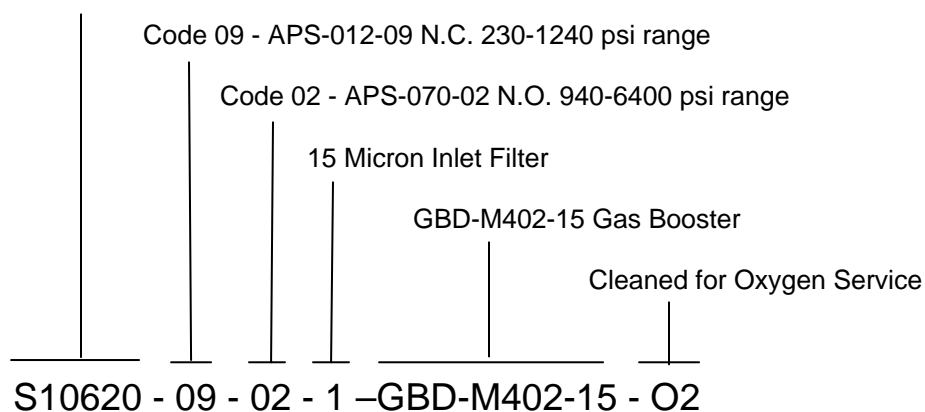

TABLE 1 Gas System Designation (based on max PSI)

S10620	System to 10,000 PSI w/ no relief valve
S10621	System to 10,000 PSI w/ 6K relief valve
S10622	System to 10,000 PSI w/ 10K relief valve
S10630	System to 20,000 PSI w/ no relief valve
S10631	System to 20,000 PSI w/ 20K relief valve
S10640	System to 25,000 PSI w/ no relief valve
S10640	System to 25,000 PSI w/ 25K relief valve

TABLE 2 Air Pilot Switch Low Side

00	No switch (standard)
XX	N.C. Use code from list on page 25

TABLE 3 Air Pilot Switch High Side

00	No switch (standard)
XX	N.O. Use code from list on page 25

TABLE 4 Gas Filter

0	No Filter
1	Filter on inlet, 15 μ (standard)
2	Filter on outlet, as specified
3	Filter on inlet and outlet

TABLE 5 Booster Model Number

Model number including modification
See "How to Order" page 22

TABLE 6

Blank	Standard Service
O2	Oxygen Service
H2	Hydrogen Service

AIR PILOT SWITCH CODES

Air pilot switch valves can be used to automatically start and stop a gas booster system so that gas supplies are not depleted completely and/or the system stops at a predetermined pressure. When using an automatic start or stop a remote pilot must be specified on the gas booster. SC Hydraulic Engineering will preset the valves to your requirements if requested.

Use this chart to select the desired air pilot switch for your gas booster system if selected as an option.

Choose a normally closed N.C. for the automatic start and a normally open N.O. for the automatic stop.

Select the proper code from column three and add to the booster system model number.

SC Hydraulic Engineering will adjust the automatic start and/or stop at the factory.

AIR PILOT SWITCH VALVE SELECTION									
Model No.*	Type	System Order Code	Sensing Port		Adjustable Range (psig) Pressure setting at factory. Specify increasing/decreasing		Air Valves 150 psig Maximum Operating Pressure		Air Valve Configure Option
			Size	Max. Pressure	Normally Closed	Normally Open	Port Size	Cv Factor	
APS-100-01	A	01	1/4" NPT	15,000 psi O ₂ = 5,000	3,500-10,000	2,400-10,000	1/8" npt	.20 UP TO 11 SCFM	N.C. & N.O.
APS-070-02		02			1,400-7,000	940-6,400			
APS-051-03		03			800-5,100	700-4,600			
APS-013-04		04			340-1,300	260-1,200			
APS-148-05		05			3,500-14,800	2,500-12,000			
APS-100-06	B	06	1/4" NPT	15,000 psi O ₂ = 5,000	3,500-10,000		1/8" npt	.13 UP TO 7 SCFM	N.C.
APS-070-07		07			1,360-7,000				
APS-050-08		08			680-5,000				
APS-012-09		09			230-1,240				
APS-005-10	A	10	1/4" NPT	3,000 psi	170-550	125-510	1/8" npt	.20 UP TO 11 SCFM	N.O. & N.C.
APS-002-11		11			70-210	50-190			
APS-001-12		12			50-130	40-130			
APS-000-13		13			25-50	20-46			
APS-005-14	B	14	1/4" NPT	3,000 psi	145-520		1/8" npt	.13 UP TO 7 SCFM	N.C.
APS-002-15		15			55-210				
APS-001-16		16			30-135				
APS-000-17		17			15-45				